



Installation

Model specific instructions

For:

- Honda VFR800 VTEC (RC46)
- Honda VFR800F (RC79)

These instructions are a model specific add-on to the general BoosterPlug installation instructions.

The general BoosterPlug installation instructions can be found in the "Downloads" section on the BoosterPlug.com website:

<http://www.boosterplug.com/shop/cms-downloads.html>

Installation Tips

- Install the BoosterPlug module as per the general installation papers.
- The pictures below should help you locate the AIT sensor where the BoosterPlug is installed.
- Remove the fuel tank. Slightly lift the air filter box to access the AIT sensor in the bottom of the air filter box.
 - NOTE ! - On the VFR800, the BoosterPlug is not installed in 10 minutes. Honda did not make things easy for you by placing the sensor under the air box. If you're not sure how to install the BoosterPlug, ask your mechanic to do it.
- You have several choices for the BoosterPlug sensor location, but our favorite place is near the steering head or under the head light. Next to the airbox snorkel air intake hole is another very good spot.
 - Just stick to the simple rules in the general installation instructions for placing the external sensor, and you'll be fine.

Pictures

For:

- Honda VFR800 VTEC (RC46)

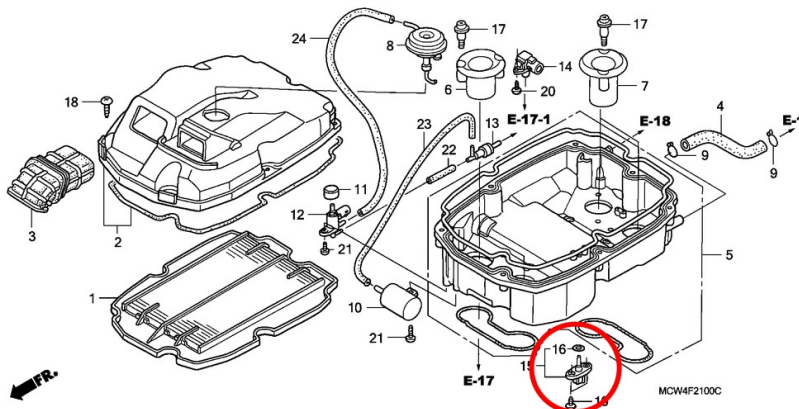

For:

- Honda VFR800F (RC79)

